

# ACS380 drive

## Quick installation and start-up guide



### To install the drive to a DIN rail

1. Move the locking part to the left.
2. Push and hold the locking button down.
3. Put the top tabs of the drive onto the top edge of the DIN installation rail.
4. Put the drive against the bottom edge of the DIN installation rail.
5. Release the locking button.
6. Move the locking part to the right.
7. Make sure that the drive is correctly installed.
8. To remove the drive, use a flat-head screwdriver to open the locking part.

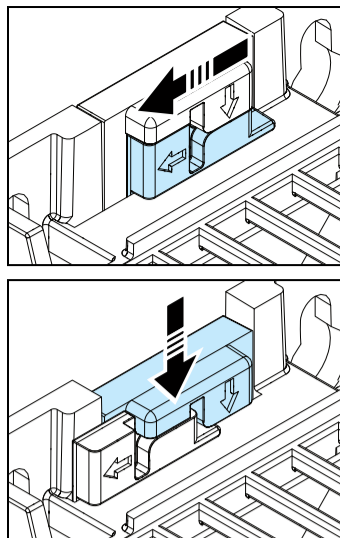

### 3. Measure the insulation resistance

**Drive:** Do not do voltage tolerance or insulation resistance tests on the drive, because this can cause damage to the drive.

**Input power cable:** Before you connect the input power cable, measure the insulation of the input power cable. Obey the local regulations.

#### Motor and motor cable:

1. Make sure that the motor cable is connected to the motor and disconnected from the drive output terminals T1/U, T2/V and T3/W.
2. Use a voltage of 500 V DC to measure the insulation resistance between each phase conductor and the protective earth conductor. The insulation resistance of an ABB motor must be more than 100 Mohm (at 25 °C/77 °F). For the insulation resistance of other motors, refer to the manufacturer's documentation. Moisture in the motor decreases the insulation resistance. If you think that there is moisture in the motor, dry the motor and do the measurement again.

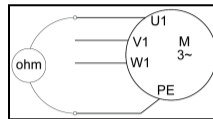

### 4. Select the cables

**Input power cable:** For the best EMC performance, use a symmetrical shielded cable and two grounding conductors.

**Motor cable:** Use a symmetrical shielded cable.

**Control cable:** Use a double-shielded twisted-pair cable for analog signals. Use a single-shielded cable for digital, relay and I/O signals. Use separate cables for analog and relay signals.

### 5. Connect the power cables

#### Connection diagram

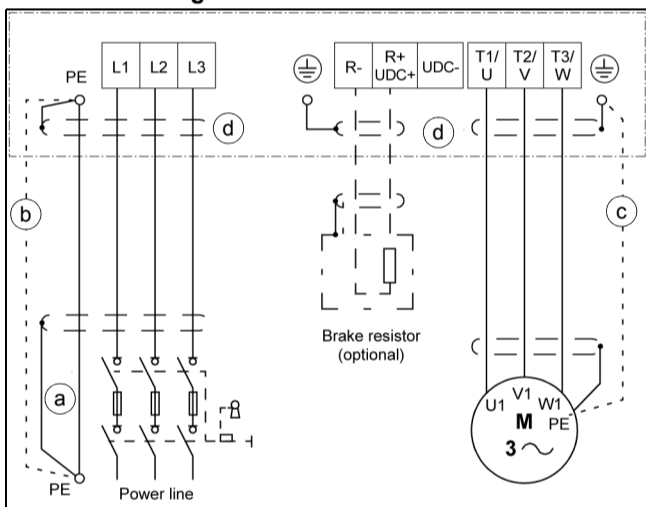

- Two grounding conductors. Use two conductors if the cross-section of grounding conductor is less than 10 mm<sup>2</sup> Cu or 16 mm<sup>2</sup> Al (IEC/EN 61800-5-1). For example, use the cable shield in addition to the fourth conductor.
- Separate grounding cable (line side). Use it if the conductivity of the fourth conductor or shield is not sufficient for the protective grounding.
- Separate grounding cable (motor side). Use it if the conductivity of the shield is not sufficient for the protective grounding, or there is no symmetrically constructed grounding conductor in the cable.
- 360-degree grounding of the cable shield. Required for the motor cable and brake resistor cable, recommended for the input power cable.

#### Connection procedure



**WARNING!** Obey the safety instructions in the *ACS380 Hardware manual* (3AXD5000029274 [English]). If you ignore them, injury or death, or damage to the equipment can occur.  
**WARNING!** If the drive is connected to an IT (non-grounded) system or to a corner-grounded TN system, disconnect the EMC filter grounding screw.

1. Strip the motor cable.
2. Ground the motor cable shield under the grounding clamp.
3. Twist the motor cable shield into a bundle, mark it accordingly and connect it to the grounding terminal.
4. Connect the phase conductors of the motor cable to the T1/U, T2/V and T3/W motor terminals. Torque the terminals to 0.8 N·m (7 lbf·in).
5. If it is applicable, connect the brake resistor cable to the R- and UDC+ terminals. Torque the terminals to 0.8 N·m (7 lbf·in). Use a shielded cable and ground the shield under the grounding clamp.
6. Strip the input power cable.
7. If the input power cable has a shield, twist it into a bundle, mark it and connect it to the grounding terminal.
8. Connect the PE conductor of the input power cable to the grounding terminal. If it is necessary, use a second PE conductor.
9. Connect the phase conductors of the input power cable to the L1, L2 and L3 input terminals. Torque the terminals to 0.8 N·m (7 lbf·in).
10. Mechanically attach the cables on the outside of the drive.

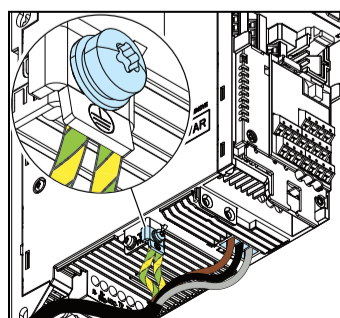
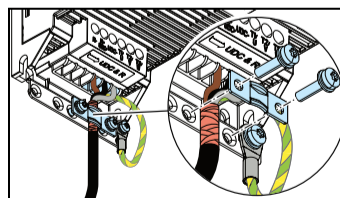

Make sure that there are no sources of strong magnetic fields such as high-current single-core conductors or contactor coils near the drive. A strong magnetic field can cause interference or inaccuracy in the operation of the drive. If there is interference, move the source of the magnetic field away from the drive.

### 6. Connect the control cables

#### Connection procedure

Do the connections according to the default control connections of the application macro that you select. For the connections of the factory default macro (ABB standard macro), refer to *Default I/O connections (ABB standard macro)*, for the connections of fieldbus default macro, refer to *Fieldbus connections*. For the other macros, refer to the *ACS380 Firmware manual* (3AXD5000029275 [English]).

Keep the signal wire pairs twisted as near to the terminals as possible to prevent inductive coupling.

1. Strip a part of the outer shield of the control cable for grounding.
2. Use a cable tie to ground the outer shield to the grounding tab.
3. Use metal cable ties for 360-degree grounding.
4. Strip the control cable conductors.
5. Connect the conductors to the correct control terminals. Torque the terminals to 0.5 N·m (4.4 lbf·in).
6. Connect the shields of the twisted pairs and grounding wires to the SCR terminal. Torque the terminals to 0.5 N·m (4.4 lbf·in).
7. Mechanically attach the control cables on the outside of the drive.

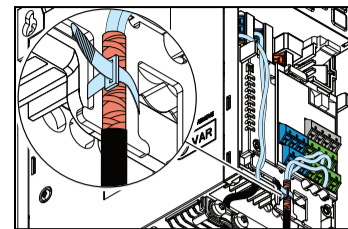

#### Default I/O connections (ABB standard macro)

For the standard variant (I/O & Modbus) (type ACS380-04xS).

Terminals	Descriptions
+24V	Digital I/O connections
DGND	Aux. +24 V DC, max. 200 mA
DCOM	Aux. voltage output common
D1	Digital input common
D2	Stop (0) / Start (1)
D3	Forward (0) / Reverse (1)
D4	Speed selection
DIO1	Speed selection
DIO2	Ramp 1 (0) / Ramp 2 (1)
DIO SRC	Ready (0) / Not ready (1)
DIO COM	Digital output auxiliary voltage
	Digital input/output common
	Analog I/O
A1	Freq. ref. / Speed ref. (0...10 V)
AGND	Analog input circuit common
A2	Not configured
AGND	Analog input circuit common
AO	Output frequency (0...20 mA)
AGND	Analog output circuit common
SCR	Signal cable shield (screen)
+10V	Reference voltage
	Safe torque off (STO)
S+	Safe torque off function. Connected at factory.
SGND	Drive starts only if both circuits are closed.
S1	
S2	
	Relay output
RC	Relay output 1
RA	No fault [Fault (-1)]
RB	
	EIA-485 Modbus RTU
B+	Embedded Modbus RTU (EIA-485)
A-	
BGND	
Shield	
Termination	

#### Connecting EIA-485 Modbus RTU terminal to drive

Connect the fieldbus to the EIA-485 Modbus RTU terminal on the BMIO-01 module which is attached on the control unit of the drive. The connection diagram is shown below.

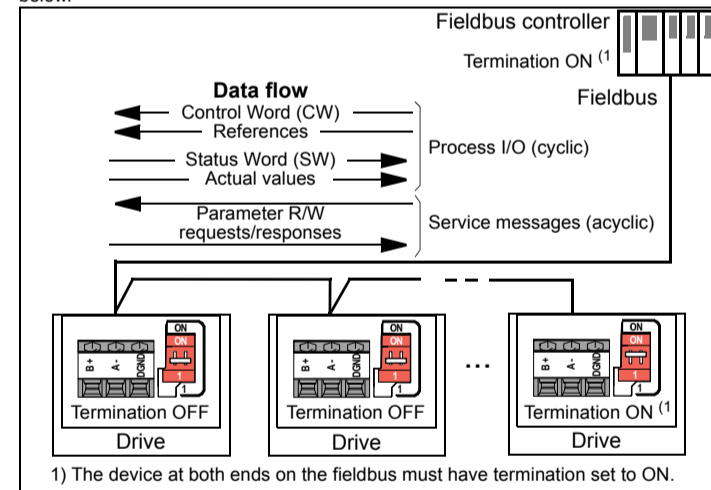

#### Fieldbus connections

For the configured drives with the preconfigured fieldbus protocol (type ACS380-04xS).

Terminals	Descriptions
+24V	Digital I/O connections
DGND	Aux. +24 V DC, 200 mA
DCOM	Aux. voltage output common
D1	Digital input common
D2	Fault reset
D3	Not configured
D4	Not configured
	Safe torque off (STO)
S+	Safe torque off function. Connected at factory.
SGND	Drive starts only if both circuits are closed.
S1	
S2	
	Relay output
RC	Relay output 1
RA	No fault [Fault (-1)]
RB	
	Extension module connections
DSUB9	CANopen
DSUB9	Profibus DP
RJ45 X 2	EtherCAT
RJ45 X 2	Ethernet IP
RJ45 X 2	Profinet
RJ45 X 2	Modbus TCP
Terminal Block	CANopen
	+K457 FCAN-01-M CANopen
	+K454 FPBA-01-M Profibus DP
	+K469 FECA-01-M EtherCAT
	+K475 FENA-21-M Ethernet/IP, Profinet, Modbus TCP
	+K495 BCAN-11 CANopen interface
	+K470 FEPL-02 Ethernet power link (RJ45x2)
	+K451 FDNA-01, DeviceNet (Terminal Block)

### Safety instructions

Read the safety instructions in *ACS380 Hardware manual* (3AXD5000029274 [EN]).

- WARNING!** Obey these safety instructions to prevent physical injury or death, or damage to the equipment. If you are not a qualified electrician, do not do electrical installation or maintenance work.
- When you install the drive, make sure that dust does not go into the drive.
  - When the drive or connected equipment is energized, do not do work on the drive, motor cable, motor, control cables or control circuits.
  - After you disconnect the input power, wait for 5 minutes to let the intermediate circuit capacitors discharge.
  - Make sure that the installation is not energized:
    - Use a multimeter with an impedance of at least 1 Mohm.
    - Make sure that the voltage between the drive output terminals (U, V, W) and the ground (PE) is 0 V.
    - Make sure that the voltage between the drive input power terminals (L1, L2, L3) and the ground (PE) is 0 V.
    - Make sure that the voltage between the DC and brake resistor terminals (UDC+, UDC- and R-) and the ground (PE) is 0 V.
  - If you use a permanent magnet synchronous motor, do not do work on the drive when the motor rotates. A permanent magnet motor that rotates energizes the drive and the input power terminals.

- WARNING!** The installation, start-up and operation of this equipment requires detailed instructions. Refer to this quick guide and the user interface guide in the drive package. Retain the guides with this device at all times. For more information, refer to the hardware manual and firmware manual. You can download these manuals from the ABB website or order hard copies of the manuals with the delivery.

### 1. Examine the installation area

The drive is intended for cabinet installation and has an ingress protection rating of IP20.

Make sure that in the installation area:

- There is sufficient cooling and hot air does not recirculate.
- The ambient conditions are suitable. Refer to *Ambient conditions*.
- The mounting surface is non-flammable and can hold the weight of the drive. Refer to *Declaration of conformity*.
- Materials near the drive are non-flammable.
- There is sufficient space above and below the drive for maintenance work. Refer to *Free space requirements*.

### 2. Install the drive

You can install the drive with screws or to a DIN rail.

Installation requirements:

- Make sure that there is a minimum of 75 mm of free space at the top and bottom of the drive for cooling air.
- Install R0 drives upright. R0 drives do not have a fan.
- You can install R1, R2, R3 and R4 drives tilted by up to 90 degrees, from vertical to fully horizontal orientation.
- You can install several drives side by side. Side-mounted options require approximately 20 mm of space on the right side of the drive.

- WARNING!** Do not install the drive upside down. Make sure that the cooling air exhaust (at the top) is always above the cooling air inlet (at the bottom).

#### To install the drive with screws

1. Make marks onto the surface for the mounting holes. Refer to *Declaration of conformity*. The R3 and R4 drives contain a mounting template.
2. Make the holes for the mounting screws and install suitable plugs or anchors.
3. Start to tighten the screws into the mounting holes.
4. Install the drive onto the mounting screws.
5. Tighten the mounting screws.

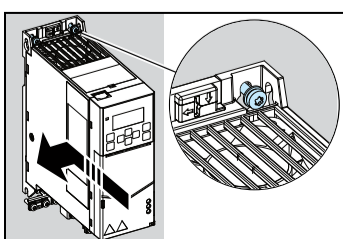
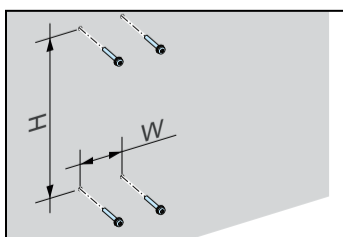

## 7. Start up the drive

For information on the user interface, refer to the *ACS380 User interface guide* (3AXD5000022224 [English]).

- Power up the drive.
- The drive software recognizes the connected adapter (I/O & Modbus module or some of the fieldbus modules) and selects the correct settings. For fieldbus communication refer also to *Configure fieldbus communications*.
- Select the unit (international or US). In the *Motor data* view, set the motor type:  
**AsynM**: Asynchronous motor  
**PMSM**: Permanent magnet synchronous motor  
**SynMR**: Synchronous reluctance motor
- Set the motor control mode:  
**Vector**: Speed reference. This is suitable for most cases. The drive does an automatic standstill ID run when the drive is started for the first time.  
**Scalar**: Frequency reference. Do not use this mode for permanent magnet synchronous motors. Use this mode when:  
 - The number of motors can change.  
 - The nominal motor current is less than 20% of the nominal drive current.
- Set the nominal motor values.
- Examine the direction of the motor. If it is necessary, set the motor direction with the **Phase order** setting or with the phase order of the motor cable.
- In the *Motor control* view, set the start and stop mode.
- Set the acceleration and deceleration times.
- Set the maximum and minimum speeds.
- In the *Control macros* view, select the applicable macro. To configure fieldbus communications, refer to *Configure fieldbus communications*.
- Tune the drive parameters to the application. You can use the Assistant control panel (ACS-AP-x) or the DriveComposer PC tool. Refer to the *ACS380 Firmware manual* (3AXD5000029275 [English]).

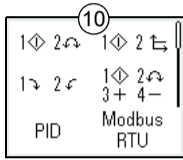
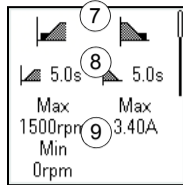
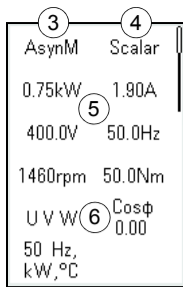

Warning	Fault	Description
	7510	FBA A communication. Communication lost between drive and fieldbus adapter.
AFF6		Identification run. The motor ID run occurs at the next start.
FA81		Safe torque off 1. The Safe torque off circuit 1 is broken.
FA82		Safe torque off 2. The Safe torque off circuit 2 is broken.

For the complete list of warnings and faults, refer to the *ACS380 Firmware manual* (3AXD5000029275 [English]).

## Ratings

### IEC ratings

Type ACS380-04xx	Input rating	Input with choke	Max. current	Output ratings						Frame size
				Nominal use		Light-duty use		Heavy-duty use		
				I <sub>N</sub>	P <sub>N</sub>	I <sub>Ld</sub>	P <sub>Ld</sub>	I <sub>Hd</sub>	P <sub>Hd</sub>	
1-phase U <sub>N</sub> = 200...240 V										
02A4-1	5.0	4.2	3.2	2.4	0.37	2.3	0.37	1.8	0.25	R0
03A7-1	7.8	6.4	4.3	3.7	0.55	3.5	0.55	2.4	0.37	R0
04A8-1	10.1	8.3	6.7	4.8	0.75	4.6	0.75	3.7	0.55	R1
06A9-1	14.5	11.9	8.6	6.9	1.10	6.6	1.10	4.8	0.75	R1
07A8-1	16.4	13.5	12.4	7.8	1.5	7.4	1.5	6.9	1.1	R1
09A8-1	20.6	17.0	14.0	9.8	2.2	9.3	2.2	7.8	1.5	R2
12A2-1	25.6	21.1	17.6	12.2	3.0	11.6	3.0	9.8	2.2	R2
3-phase U <sub>N</sub> = 200...240 V										
02A4-2	3.8	2.4	2.2	2.4	0.37	2.3	0.37	1.2	0.25	R1
03A7-2	5.9	3.7	3.2	3.7	0.55	3.5	0.55	1.8	0.37	R1
04A8-2	7.7	4.8	6.7	4.8	0.75	4.6	0.75	3.7	0.55	R1
06A9-2	11.0	6.9	8.6	6.9	1.1	6.6	1.1	4.8	0.75	R1
07A8-2	12.5	7.8	12.4	7.8	1.5	7.4	1.5	6.9	1.1	R1
09A8-2	15.7	9.8	14.0	9.8	2.2	9.3	2.2	7.8	1.5	R1
12A2-2	19.5	12.2	17.6	12.2	3.0	11.6	3.0	9.8	2.2	R2
17A5-2	28.0	17.5	22.0	17.5	4.0	16.7	4.0	12.2	3.0	R3
25A0-2	40.0	25.0	31.5	25.0	5.5	24.2	5.5	17.5	4.0	R3
032A-2	51.2	32.0	45.0	32.0	7.5	30.8	7.5	25.0	5.5	R3
048A-2	76.8	48.0	57.6	48.0	11.0	46.2	11.0	32.0	7.5	R4
055A-2	88.0	55.0	66.4	55.0	15.0	52.8	15.0	48.0	11.0	R4
3-phase U <sub>N</sub> = 380...480 V										
01A8-4	2.9	1.8	2.2	1.8	0.55	1.7	0.55	1.2	0.37	R0
02A6-4	4.2	2.6	3.2	2.6	0.75	2.5	0.75	1.8	0.55	R1
03A3-4	5.3	3.3	4.7	3.3	1.1	3.1	1.1	2.6	0.75	R1
04A0-4	6.4	4.0	5.9	4.0	1.5	3.8	1.5	3.3	1.1	R1
05A6-4	9.0	5.6	7.2	5.6	2.2	5.3	2.2	4.0	1.5	R1
07A2-4	11.5	7.2	10.1	7.2	3.0	6.8	3.0	5.6	2.2	R1
09A4-4	15.0	9.4	13.0	9.4	4.0	8.9	4.0	7.2	3.0	R1
12A6-4	20.2	12.6	16.9	12.6	5.5	12.0	5.5	9.4	4.0	R2
17A0-4	27.2	17.0	22.7	17.0	7.5	16.2	7.5	12.6	5.5	R3
25A0-4	40.0	25.0	30.6	25.0	11.0	23.8	11.0	17.0	7.5	R3
032A-4	45.0	32.0	45.0	32.0	15.0	30.5	15.0	25.0	11.0	R4
038A-4	50.0	38.0	57.6	38.0	18.5	36.0	18.5	32.0	15.0	R4
045A-4	56.0	45.0	68.4	45.0	22.0	42.8	22.0	38.0	18.5	R4
050A-4	60.0	50.0	81.0	50.0	22.0	48.0	22.0	45.0	22.0	R4

3AXD10000299801.xls

### NEMA ratings

Type ACS380-04xx	Input rating	Input with choke	Output ratings				Frame size
			Nominal use		Heavy-duty use		
			I <sub>N</sub>	P <sub>N</sub>	I <sub>Ld</sub>	P <sub>Ld</sub>	
3-phase U <sub>N</sub> = 460 V (440...480 V)							
01A8-4	2.6	1.6	1.6	0.75	1.1	0.50	R0
02A6-4	3.4	2.1	2.1	1.0	1.6	0.75	R1
03A3-4	4.8	3.0	3.0	1.5	2.1	1.0	R1
04A0-4	5.4	3.4	3.5	2.0	3.0	1.5	R1
05A6-4	7.7	4.8	4.8	2.0	3.4	2.0	R1
07A2-4	9.6	6.0	6.0	3.0	4.0	2.0	R1
09A4-4	12.2	7.6	7.6	5.0	4.8	3.0	R1
12A6-4	17.6	11.0	11.0	7.5	7.6	5.0	R2
17A0-4	22.4	14.0	14.0	10.0	11.0	7.5	R3
25A0-4	33.6	21.0	21.0	15.0	14.0	10.0	R3
032A-4	37.9	27.0	27.0	20.0	12.0	15.0	R4
038A-4	44.7	34.0	34.0	25.0	27.0	20.0	R4
045A-4	49.8	40.0	40.0	30.0	34.0	25.0	R4
050A-4	50.4	42.0	42.0	30.0	40.0	30.0	R4

3AXD10000299801.xls

### Fuses

For more information on fuses, circuit breakers and manual motor protectors, refer to the *ACS380 Hardware manual* (3AXD5000029274 [English]).

### Dimensions and weights

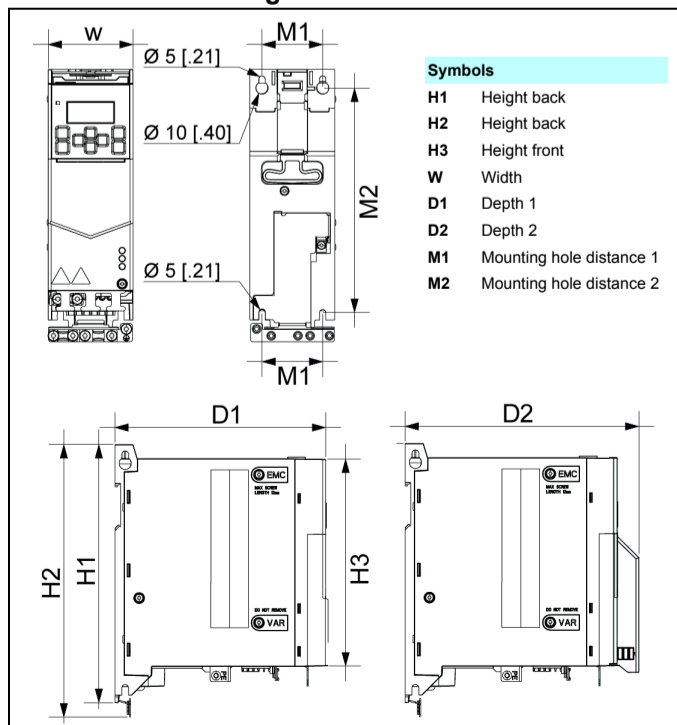

Frame size	Dimensions and weights																	
	H1		H2		H3		W		D1		D2		M1		M2		Weight	
	mm	in	mm	in	mm	in	mm	in	mm	in	mm	in	mm	in	mm	in	kg	lb
R0	205	8.07	223	8.78	170	6.69	70	2.76	174	6.85	191	7.52	50	1.97	191	7.52	1.4	3.1
R1	205	8.07	223	8.78	170	6.69	70	2.76	174	6.85	191	7.52	50	1.97	191	7.52	1.6	3.5
R2	205	8.07	223	8.78	170	6.69	95	3.74	174	6.85	191	7.52	75	2.95	191	7.52	1.9	4.2
R3	205	8.07	223	8.78	170	6.69	169	6.65	181	7.13	191	7.52	148	5.83	191	7.52	2.9	6.4
R4	205	8.07	240	9.45	170	6.69	260	10.24	181	7.13	191	7.52	238	9.37	191	7.52	5.8	12.8

3AXD10000299801.xls

### Free space requirements

Frame size	Free space required										
	Above		Below		Sides						
	mm	in	mm	in	mm	in					
R0-R4	75		2.95		75		2.95		0		0

3AXD10000299801.xls

### Ambient conditions

Requirement	During operation (installed for stationary use)
Installation altitude	230 V units: 0...2000 m above sea level (with derating above 1000 m) 400 V units: 0...4000 m above sea level (with derating above 1000 m) <sup>1)</sup>
Air temperature	-10...+50 °C (14...122 °F). Up to +60 °C with derating (except R0). No frost allowed.
Relative humidity	Up to 95% without condensation
Contamination levels (IEC 60721-3-3)	Class 3C2 Class 3S2
Shock (IEC 60068-2-27, IATA 1A)	Not allowed
Free fall	Not allowed

1) Up to 4000 m altitude is possible for 400 V units when these conditions are taken into account:

- The maximum switching voltage for integrated Relay Output 1 is 30 V at 4000 m (for example, do not connect 250 V to Relay Output 1).
- With the BREL-01 side option module, the maximum potential difference between adjacent relays is 30 V (for example, do not connect 250 V to Relay Output 2 and 30 V to Relay Output 3).
- If the conditions are not met, the maximum installation altitude is 2000 m.
- For a 3-phase 400 V drive at 2000...4000 m, only the following power systems are permitted: TN-S, TN-C, TN-CS, TT (not corner earthed).

### Certifications

The applicable certifications are shown on the product's type label.



### Declaration of conformity

Power and productivity for a better world™ **ABB**

### EU Declaration of Conformity

Low Voltage Directive 2014/35/EU and EMC Directive 2014/30/EU

We  
 Manufacturer: ABB Oy  
 Address: Hiomotie 13, 00380 Helsinki, Finland.  
 Phone: +358 10 22 21 11

declare under our sole responsibility that the following product  
**Frequency converter**  
**ACS380-04xx (frames R0 – R2, 1ph 200 - 240Vac)**  
**ACS380-04xx (frames R0 – R4, 3ph 380 - 480Vac)**  
**ACS380-04xx (frames R1 – R4, 3ph 200 – 240Vac)**

is in conformity with the relevant requirements of Low Voltage Directive 2014/35/EU and EMC Directive 2014/30/EU, provided that the equipment is selected, installed and used according to given instructions.

The following harmonized standards have been applied:  
 EN 61800-5-1:2007  
 EN 61800-3:2004 + A1:2012

Adjustable speed electrical power drive systems - Part 5-1: Safety requirements - Electrical, thermal and energy  
 Adjustable speed electrical power drive systems - Part 3: EMC requirements and specific test methods

The product referred in this Declaration of conformity fulfils the relevant provisions of other European Union Directives which are notified in Single EU Declaration of conformity 3AXD10000495941.

Helsinki, 23<sup>rd</sup> March 2018

Manufacturer representative:  
 Vesa Kandell  
 Vice President, ABB Oy

### Configure fieldbus communications

If you have a configured variant with the preconfigured fieldbus protocol, you can control the drive from an external control system through the fieldbus.

When the fieldbus adapter is connected to the drive, the drive control program sets the applicable parameters. The preconfigured settings apply to the CANopen, EtherCAT, Profibus and Profinet (default in FENA-21 adapter) protocols. If you have a CANopen variant with the BCAN-11 adapter, refer to the exceptions in the table. In other fieldbus protocols (DeviceNet, Powerlink,...) refer to *ACS380 Firmware manual* (3AXD5000029275 [English]) and the applicable fieldbus adapter documentation.

To configure fieldbus communications:

- Power up the drive.
- The drive software recognizes the connected fieldbus adapter and selects the correct fieldbus control macro. The changed parameters which apply to all fieldbus adapters:

Parameter	Setting (general)	Setting (CANopen with BCAN-11)
20.01 Ext1 commands	Fieldbus A	Embedded fieldbus
20.03 Ext1 in1	Not selected	Not selected
20.04 Ext1 in2	Not selected	Not selected
22.11 Ext1 speed ref1	FB A ref1	EFB ref1
22.22 Constant speed sel1	Not selected	Not selected
22.23 Constant speed sel2	Not selected	Not selected
23.11 Ramp set selection	Acc/Dec time 1	Acc/Dec time 1
28.11 Ext1 frequency ref1	FB A ref1	EFB ref1
28.22 Constant frequency sel1	Not selected	Not selected
28.23 Constant frequency sel2	Not selected	Not selected
28.71 Freq. ramp set selection	Acc/Dec time 1	Acc/Dec time 1
31.11 Fault reset selection	DI2	DI1
50.01 FBA A enable	Enable	N/A
50.02 FBA A comm loss func	Fault	N/A

The parameters that apply only to specific fieldbus adapters:

Parameter	Setting
<b>CANopen (FCAN-01-M)</b>	
51.05 Profile	CiA 402
<b>EtherCAT</b>	
51.02 Profile	CiA 402
<b>Profibus</b>	
51.02 Node address	3
51.05 Profile	ABB Drives
52.01 FBA A data in1	SW 16 bit
52.02 FBA A data in2	Act1 16 bit
53.01 FBA A data out1	CW 16 bit
53.02 FBA A data out2	Ref1 16 bit
<b>Profinet</b>	
51.02 Protocol/Profile	PNIO ABB Pro
51.04 IP configuration	Static IP
52.01 FBA A data in1	SW 16 bit
52.02 FBA A data in2	Act1 16 bit
53.01 FBA A data out1	CW 16 bit
53.02 FBA A data out2	Ref 1 16 bit
<b>Modbus TCP/IP</b>	
51.02 Protocol/Profile	MB/TCP ABB C
<b>Ethernet IP</b>	
51.02 Protocol/Profile	EIP ABB Pro
<b>CANopen (BCAN-11)</b>	
58.01 Protocol enable	CANopen

- You can see the selected fieldbus control macro in the *Control macros* view or from parameter 96.05. In the *Control macros* view, you can also change some adapter specific settings.
- If you need to change other parameters, you can set them manually. Refer to the *ACS380 Firmware manual* (3AXD5000029275 [English]) and the applicable fieldbus adapter documentation.

### Warnings and faults generated by the drive

Warning	Fault	Description
A2A1	2281	Warning: